



Measuring System of Temperature, Humidity, and Light Intensity for Plant Monitoring in BALITJESTRO, Batu City

Received
21 February 2020

Revised
04 March 2021

Accepted for Publication
22 June 2021

Published
24 June 2021

T A Ansyah^{1*}, Heriyanto¹, and B A Fansuri²

- ¹. Department of Physics, Faculty of Mathematics and Natural Sciences, Universitas Negeri Malang, Jl. Semarang 5, Malang, 65115, Indonesia.
- ². Research Center for Citrus and Subtropical Fruits (BALITJESTRO), Jl. Tlekung 1, Batu, 65327, Indonesia.

*E-mail: tomyandreansyah@gmail.com



This work is licensed under a [Creative Commons Attribution-ShareAlike 4.0 International License](https://creativecommons.org/licenses/by-sa/4.0/)

Abstract

Therefore, a tool is needed to make it easier for researchers, so there is no need to go back and forth to retrieve data. This research has the following research method stages, (1) literature study of theories to design the system from the tools to be made, (2) system design, (3) analysis of device requirements, (4) tool calibration process (data can be said to be valid if the error does not exceed 1%), and (5) data processing is according to agricultural research needs. In this research, a tool that has calibrated with an appropriate measuring instrument produced. Measuring temperature, humidity, and light intensity designed with a microcontroller and other sensors with a data storage base on an SD card. The measuring results show that the temperature values fluctuate between 16.9 °C to 28.2 °C. The value of air humidity tends to remain at the value of 99.9%. At the same time, the value of light intensity ranges from 202 to 606 Cd. The relative error of temperature, humidity, and light intensity is 0.007%, 0.082%, and 0.016%. Therefore, each measurement indicator has a relative error value of <1% so that the designed tool has valid and under the standardized measuring instrument.

Keywords: Data logger, temperature, humidity, intensity.

1. Introduction

One of the factors that are closely related to plant growth and development is environmental factors. More specifically, the environmental factors in question are ambient temperature, sunlight intensity, and air humidity. The right and optimal temperature and humidity are needed to achieve the best plant quality. Conditions of temperature and/or humidity that are too high can result in plant death. On the other hand, sufficient sunlight is needed by plants as energy for photosynthesis, processing mineral materials from the soil and producing nutrients [1].

Apple (*Malus sylvestris*) is one of the fruit crop commodities which can cultivate in Indonesia's territory. This commodity is an annual plant originating from the subtropics [2]. Apples are cultured in vitro and contain phenolic compounds that can prevent cancer and show antioxidant activity [3]. Apple cultivation requires more than 1000 hours of cold weather with an average temperature of 16–27 °C. Temperatures that are too high or too low will significantly affect the quality of the fruit produced. Apple cultivation also depends on irrigation and environmental factors. Furthermore, there is a direct relationship between temperature patterns and irrigation requirements for apple cultivation. In addition, climatic factors (especially rainfall) also play a significant role in the productivity of apple plants [4]. So that an environmental study based on an automatic measuring device is needed to reveal some of the constraints and optimal environmental conditions to optimize the production of apple cultivation [5].

Batu City is an area with a regional agro-climate that supports the cultivation of horticultural commodities, one of which is apples [6]. The abundance of apples in Batu City and its surroundings has encouraged many MSMEs and home industries to produce various apple-based processed foods [7]. One of the research institutions in Batu City tasked with researching subtropical fruit is the Research Institute for Citrus and Subtropical Plants (BALITJESTRO). BALITJESTRO is located at an altitude

of ± 950 m above sea level, precisely under the foot of Mount Panderman, Tlekung Village, Junrejo District, Batu City, East Java [8]. Data on environmental temperature, light intensity, and air humidity are needed at the research centre to take solutions for plant cultivation. The location of the observed plant objects is often far in the middle of the mountains, causing periodic data collection to take a long time and is inefficient.

Technological developments have been used in various fields of science, including agriculture. Technological support in agriculture has proven to provide better production results, especially data synchronization and time efficiency [9]–[11]. Therefore, this study seeks to design a measuring device for environmental temperature, light intensity, and air humidity to support the monitoring of plant growth and development in BALITJESTRO. The tool is designed with a practical design, so it is easy to carry anywhere. The value of the measurement results can be known directly through the LCD screen and the monitoring file is stored in the SD card (data logger system). A data logger is an electronic device connected to a sensor that functions to record data periodically [12]. In addition, the data obtained can be processed according to the needs of agricultural research, one of which is a graph of changes in environmental factors. These results can be used as further analysis in identifying environmental factors on plant growth and development.

2. Method

This research has four stages of research methods. First, literature study of theories related to the results of problem identification to design the system of the tool to be made. Second, system design based on the theories that have been obtained. Third, needs analysis includes the needs and integration of software and hardware following the plans that have been made. The last stage is the tool calibration process. The data obtained is said to be valid if the data error value does not exceed 1%.

2.1. Hardware Design

The hardware design contains the design of a series of electronic devices used to make tools. The electronic circuit used in measuring environmental temperature, humidity, and light intensity can be seen in Figure 1. Part (a) is a battery as a voltage source for the appliance. The battery used has a potential difference of 9 volts. Part (b) is Arduino Mega 2560 microcontroller with ATmega2560 chip [13]. Part (c) is switching with two main buttons. Part (d) is the SD card module. Part (e) is the RTC DS3231. Part (f) is the DHT22 module. Part (g) is the LDR sensor. Last, part (h) is a 16×2 LCD as a data viewer.

The temperature and humidity sensor used in this study is the DHT22 module. One of the advantages of DHT22 is that the output signal can be transmitted via cables up to 20 meters long [14]. The DHT22 module is a recessive element. The DHT22 module also has an advantage in reading the quality of the sensing data that is more responsive. In addition, the module also has a reasonably fast speed in terms of temperature and humidity sensing. So that the readable data can be easily interpreted [15].

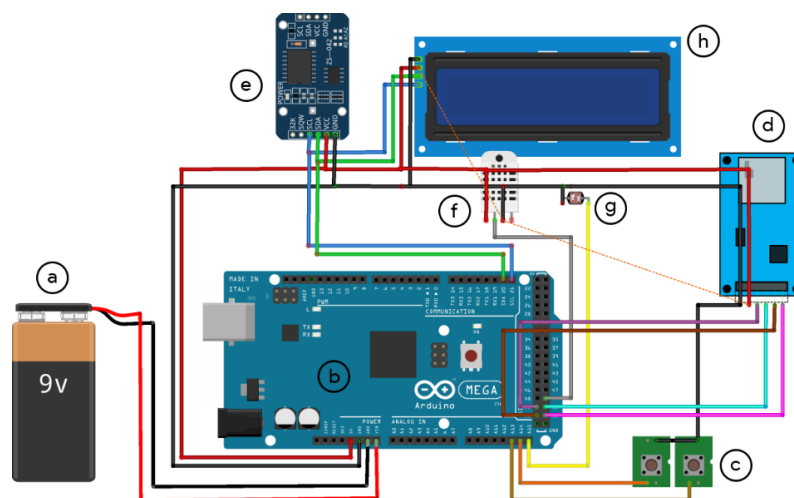

Figure 1. Electronic circuit design.

Table 1. Modules and pins used in the design.

Pin	Module
D49	DHT22
A15	LDR sensor
D20, D21	I2C
D20, D21	RTC DS3231
D50,D51,D52,D53	SD card module
A13,A14	Switching

The light intensity sensor used in this study is an LDR sensor (light dependent resistor). LDR is a type of resistor with resistance changes depending on the size of the light intensity received [16]. When the LDR sensor is subjected to high light intensity, the resistance value is low and the LDR becomes a good conductor [17]. For RTC and I2C on the LCD, pin D21 is used for SCL (Serial Clock) and D20 for SDA (Serial Data). A device connected to an I2C (Inter-Integrated Circuit) system can be operated as Master or Slave. Master is a device that ends or starts data transfer on I2C by generating a Start or Stop signal and can also generate a clock signal. The slave is a device that is addressed by the master [18]. I2C relies on an address scheme to communicate [19]. The RTC used is the DS3231, an accurate real-time I2C clock with a Temperature Compensated Crystal Oscillator (TCXO) and an integrated crystal. In this device, there is an input for the battery that maintains accurate timekeeping when the main power to the device is disconnected [20]. The modules and pins used in the design are shown in Table 1.

2.2. Arduino Program Design

The program begins with the initialization of the SD Card and other sensors used. If the “Menu” button (part (c) in Figure 1) is pressed, the program will automatically switch to the clock setting. When the Arduino has appropriately initialized all the tools, data will begin to be taken by the sensor and then sent to the microcontroller. When Arduino has received the data, that will be displayed on the 16×2 LCD that has been prepared. Besides displayed on the LCD, data will also be saved in the SD card previously installed on the module every 10 minutes.

2.3. Tool Calibration

Calibration is the process of equalizing the measurements of the tools that have made with standardized measuring devices. This calibration needs to do so that the measurement results from the designed tools can match reality. For example, the temperature measurement component calibrated with a thermometer, the humidity component calibrated with a hygrometer, and the light intensity component calibrated with a luxmeter. The relative error measurement is determined using Equation 1.

$$\text{Relative Error} = \frac{(DT + CT)}{CT} \times 100\% \quad (1)$$

DT is the measurement value of design tool and CT is the measurement value of calibration tool.

3. Results and Discussion

This section contains the realization of the greenhouse monitoring system, which includes several parts, namely how the system works, hardware, and software of the tool. First, system works are presented in the form of a workflow to understand the overall work process of the system. Second, the hardware section discusses the devices used, such as the data retrieval process. Next, the software discusses the data processing process. Finally, based on the data taken, an analysis will be carried out on the work process. From here, conclusions can be obtained.

3.1. Block Diagram of Measuring Tool Work System

The working principle of the tool system that has designed shown in Figure 2. The sensors used to consist of sensors of temperature, humidity, and light intensity. After the sensor takes measurements, the data is sent to the microcontroller and stored in the SD card connected to the module. Finally, the processed data will be displayed via a 16×2 LCD. SD Card reader modules generally designed using an

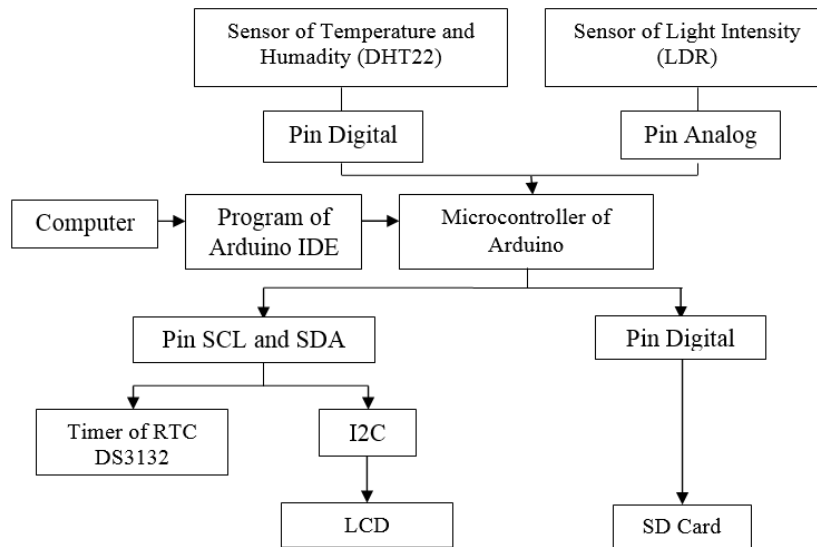

Figure 2. Block diagram of measuring tool work system.

SPI (Serial Peripheral Interface) interface [21]. LCD or Liquid Crystal Display (LCD) is a device that often used to display data. LCD serves as a means of communication with humans in the form of writing or images. To connect the microcontroller to LCD, it is necessary to configure the pins on the LCD with the ports on the microcontroller [22].

3.2. Device Implementation Results

After the physical form of the electronic system with an integrated network implement, complete hardware will be obtained. The electronic devices used include the Arduino Mega 2560 microcontroller along with sensors and other modules. The design of the tool shown in Figure 3.

The “Menu” button and the “Ganti” button (part (c) in Figure 1) use to enter the date and time settings. If the “Menu” button press, it will enter the initial function of setting the date and time, which indicate by two flashing digits on the top-left of the LCD. After that, we can press the “Ganti” button until the clock is correct. When the “Menu” button press again, it will enter the minutes setting. The “Ganti” button uses to set the appropriate minute digits. Then the “Menu” button is pressed again, it will enter the date setting. Press the “Ganti” button to select the proper date digit. Press the “Menu” button again to enter the month setting. Press the “Ganti” button to choose the appropriate month digit. Then the “Menu” button is pressed again. It will enter the year setting. Press the “Ganti” button to select the proper year digit (the year shown on the screen is the last two digits of the year 20xx). Finally, press the “Menu” button again to end the date and time setting.

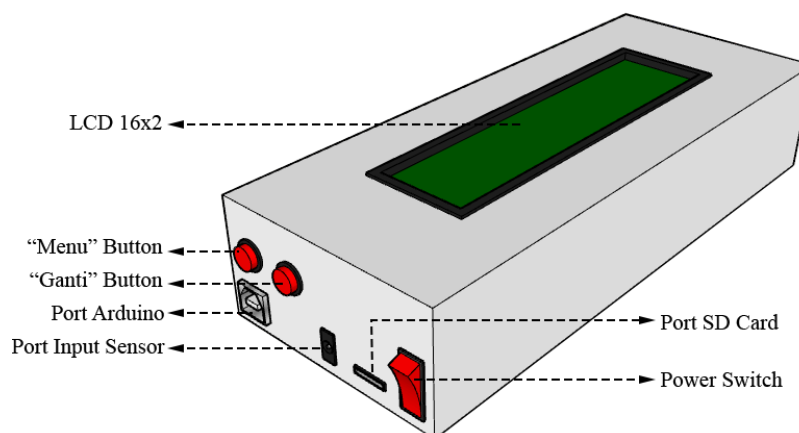

Figure 3. Design of the tool.

Tanggal	Waktu	Temperatur	Kelembaban	Intensitas
16/10/2019	00:05:26	18.4	99.9 %	326
16/10/2019	00:15:25	18.3	99.9 %	359
16/10/2019	00:25:23	18.0	99.9 %	315
16/10/2019	00:35:21	17.9	99.9 %	350
16/10/2019	00:45:19	17.8	99.9 %	321
16/10/2019	00:55:18	17.8	99.9 %	350
16/10/2019	01:05:16	17.8	99.9 %	332
16/10/2019	01:15:14	17.8	99.9 %	334
16/10/2019	01:25:12	17.8	99.9 %	343
16/10/2019	01:35:11	17.8	99.9 %	329
16/10/2019	01:45:09	17.8	99.9 %	326
16/10/2019	01:55:07	17.8	99.9 %	353
16/10/2019	02:05:05	17.8	99.9 %	318
16/10/2019	02:15:04	17.8	99.9 %	359
16/10/2019	02:25:02	17.7	99.9 %	362
16/10/2019	02:35:00	17.6	99.9 %	366
16/10/2019	02:44:59	17.6	99.9 %	366
16/10/2019	02:54:57	17.6	99.9 %	340
16/10/2019	03:04:55	17.4	99.9 %	362
16/10/2019	03:14:53	17.4	99.9 %	334
16/10/2019	03:24:52	17.3	99.9 %	359
16/10/2019	03:34:50	17.2	99.9 %	366
16/10/2019	03:44:48	17.2	99.9 %	353

Figure 4. The resulting Logger.txt data.

Table 2. Measuring data.

Parameter	Temperature (°C)	Humadity (%)	Light Intensity (Cd)
Maximal	28.2	99.9	606
Minimal	16.9	99.9	202
Average	22.1	99.9	332

3.3. Data Storage

The data that has taken will store on the SD card that has installed. The data will be entered automatically into the Logger.txt file. The file name can be changed as long as the file name in the Arduino program is also changed according to the name of the file used as data storage (all letters must match, capital or ordinary letters also affect). The data stored is relatively small. Data collection is carried out every 10 minutes for two days. The resulting Logger.txt data size after the measurement is approximately 13.3 KB. The temperature, humidity, and light intensity measurement data stored in Logger.txt shown in Figure 4.

3.4. Discussion

The test carried out for two days, on 16 and 17 October 2019, in the BALITJESTRO Batu greenhouse. The tools and sensors placed in the greenhouse room. The data of time, temperature, humidity, and light intensity has taken about every 10 minutes using the wake-up interrupt function of the RTC (Real Time Clock) module. RTC with the addition of the wake-up interrupt method used for more precise time synchronization [23]. During the two days of measurement, 289 data were obtained. The data obtained briefly presented in Table 2.

3.5. Calibration Result

Based on Equation (1), the relative error of temperature for the designed tool to the thermometer is 0.007%, the relative error of air humidity for the designed tool to the hygrometer is 0.082%, and the relative error of intensity for the designed instrument to the luxmeter is 0.016%. Therefore, each measurement indicator has a relative error value of <1%, so that the designed tool has valid and under the standardized measuring instrument.

4. Conclusion

Measurement of temperature, humidity, and light intensity using SD card-based sensors with Arduino Mega to increase the effectiveness of agricultural research at BALITJESTRO has been under standard measuring instruments. The designed tool has an accuracy of up to 0.1 °C in temperature measurement. Based on temperature calibration with a thermometer, temperature obtained a relative error of 0.007%. The designed tool has an accuracy of up to 0.1% in the measurement of air humidity. Based on the humidity calibration with a hygrometer, humidity obtained a relative error of 0.082%. The designed

tool has an accuracy of up to 1 Cd in measuring light intensity. Based on the light intensity calibration with a luxmeter, light intensity obtained a relative error of 0.016%. The measuring results show that the temperature values fluctuate between 16.9 °C to 28.2 °C. The value of air humidity tends to remain at the value of 99.9%. At the same time, the value of light intensity ranges from 202 to 606 Cd.

Acknowledgement

Acknowledgements addressed to all parties, especially to the Universitas Negeri Malang and BALITJESTRO Batu, who have assisted in the overall implementation of the research until the completion of the article manuscript.

References

- [1] C. T. Harwati, “Pengaruh suhu dan panjang penyinaran terhadap umbi kentang (*Solanum tuberosum*, ssp.),” *INNOFARM: J. Inov. Pertanian*, vol. 7, no. 1, pp. 11–18, 2018.
- [2] D. S. T. Anggara, A. Suryanto, and A. Ainurrasjid, “Kendala produksi apel (*Malus sylvestris* Mill.) var. manalagi di Desa Poncokusumo Kabupaten Malang,” *J. Produksi Tanam.*, vol. 5, no. 2, pp. 198–207, 2017.
- [3] E. W. Budiman, R. P. Sudibyoy, and I. Baroh, “Analisis kelayakan usaha budidaya apel (Studi kasus di Desa Bumi Aji Kecamatan Bumi Aji Kota Batu),” *VIABEL: J. Ilm. Ilmu-Ilmu Pertanian*, vol. 12, no. 1, pp. 1–8, 2018.
- [4] N. Herlina and F. Amrulah, “Hubungan curah hujan dengan produktivitas apel (*Malus sylvestris* Mill.) di Kabupaten Pasuruan, Jawa Timur,” *J. Tanah dan Iklim*, vol. 44, no. 1, p. 11–18, 2020.
- [5] F. Nabi, S. Jamwal, and K. Padmanbh, “Wireless sensor network in precision farming for forecasting and monitoring of apple disease: A survey,” *Int. J. Inf. Technol.*, 2020.
- [6] R. Sari, “Analisis efisiensi pemasaran buah apel di Desa Bumiaji Kecamatan Bumiaji Kota Batu,” S.P. Undergraduate Thesis, Dept. of Agribusiness, Univ. Islam Malang, Malang, Indonesia, 2020.
- [7] T. Estiasih, “Peningkatan kinerja pada proses produksi olahan berbasis apel di UKM TM Mandiri dan Mulyo Agro Mandiri, Kota Batu,” *Teknol. Pangan: Media Inf. Komun. Ilm. Teknol. Pertan.*, vol. 8, no. 2, pp. 188–195, 2017.
- [8] Balai Penelitian Tanaman Jeruk dan Buah Suptropika, “Sejarah,” Balitjestro, <http://balitjestro.litbang.pertanian.go.id/profil/sejarah/> (accessed Nov. 03, 2019).
- [9] I. Artana, D. M. Wiharta, and L. Linawati, “Rancang bangun pertanian stroberi berbasis internet of things,” *J. Spektrum*, vol. 7, no. 4, pp. 1–6, 2020.
- [10] R. Susana, M. Ichwan, and S. A. Phard, “Penerapan metoda serial peripheral interface (SPI) pada rancang bangun data logger berbasis SD card,” *J. Elkomika*, vol. 4, no. 2, pp. 208–227, 2016.
- [11] U. Fadlilah and N. Saniya, “Monitoring suhu kabel trafo melalui tampilan LCD dan SMS,” *Emitor: J. Tek. Elektro*, vol. 17, no. 2, pp. 42–49, 2017.
- [12] A. H. Saptadi, D. Kurnianto, and Suyani, “Rancang bangun thermohyrometer digital menggunakan sistem mikropengendali arduino dan sensor DHT22,” in *Prosiding Seminar Nasional Sains dan Teknologi (SNST) Ke-6 Tahun 2015*, 2015, pp. 83–88.
- [13] R. Arpianto, H. Priyatman, and D. Suryadi, “Rancang bangun alat identifikasi nominal uang kertas untuk tunanetra berbasis arduino mega 2560 dengan ouput suara,” *J. Teknik Elek. Univ. Tanjungpura*, vol. 1, no. 1, pp. 1–10, 2018.
- [14] R. D. Shafarianto, “Implementasi pemantauan dan pengendalian suhu, kelembaban dan penyinaran pada pembibitan tanaman angrek *cattleya* secara otomatis pada greenhouse berbasis web,” Dr. dissertation, Dept. Inform., Univ Muhammadiyah Malang, Malang, 2019.
- [15] A. Faroqi, M. R. Efendi, D. T. Ismail, and W. Darmalaksana, “Design of arduino uno based duck egg hatching machine with sensor DHT22 and PIR sensor,” in *Proc. 6th Int. Conf. Wirel. Telemat. ICWT 2020*, 2020, pp. 14–17.
- [16] D. Nusyirwan, M. D. Aritonang, and P. P. P. Perdana, “Penyaringan air keruh menggunakan sensor LDR dan bluetooth HC-05 sebagai media pengontrolan guna meningkatkan mutu kebersihan air di sekolah,” *LOGISTA: J. Ilm. Pengabd. Kepada Masyarakat*, vol. 3, no. 1, pp. 37–46, 2019.
- [17] H. Santoso, *Panduan Praktis Arduino untuk Pemula*. Trenggalek: Elang Sakti, 2015.

- [18] P. Giashinta, "Alat pengatur suhu kelembaban dan monitoring masa panen pada budidaya jamur tiram berbasis arduino uno," D.T. Undergraduate Thesis, Dept. Electronic Eng., Univ. Negeri Yogyakarta, Yogyakarta, 2018.
- [19] D. Trivedi, A. Khade, K. Jain, and R. Jadhav, "SPI to I2C protocol conversion using verilog," in *Proc. 4th Int. Conf. Comput. Commun. Control Autom. ICCUBEA 2018*, pp. 1–4, 2018.
- [20] Y. Widiawati and P. H. Islam, "Pemanfaatan RTC (real time clock) DS3231 untuk menghemat daya," in *Pros. Semin. Nas. Tek. Elektro*, vol. 3, pp. 287–289, 2018.
- [21] M. Darwisa, "Penambahan fitur tampilan LCD dan micro SD card reader pada mesin laser engraver and cutter di laboratorium pengemudian listrik," *J. Pengelolaan Lab. Pendidik.*, vol. 2, no. 1, pp. 8–18, 2020.
- [22] I. Purwanti and Suyatno, "Rancang bangun smart class untuk menghemat pemakaian listrik menggunakan arduino mega 2560," *eMIT*, vol. 2, no. 2, pp. 1–10, 2020.
- [23] A. Geraldo, S. R. Akbar, and R. Primananda, "Implementasi low power pada wireless sensor node untuk akuisisi data lahan pertanian dengan metode wake up interrupt modul RTC," *J. Pengembang. Teknol. Inf. Ilmu Komput. Univ. Brawijaya*, vol. 3, no. 1, pp. 546–553, 2019.