

SYNCHRONOUS AC CHOPPER FOR UNIVERSAL MOTOR SPEED CONTROL USING FUZZY LOGIC

Andi Setiawan¹, Widjonarko², Candrika Kumaratungga³

¹Department of Electrical Engineering, Jember University Jln. Kalimantan no 37, Krajan Timur, Sumbersari, Jember 68121, Indonesia
setiawan.teknik@unej.ac.id

²Department of Electrical Engineering, Jember University Jln. Kalimantan no 37, Krajan Timur, Sumbersari, Jember 68121, Indonesia
widjonarko.teknik@unej.ac.id

³Department of Electrical Engineering, Jember University Jln. Kalimantan no 37, Krajan Timur, Sumbersari, Jember 68121, Indonesia saya.candri@gmail.com

Corresponding: widjonarko.teknik@unej.ac.id

Abstract

The use of Universal type motorcycles is very commonly used, both in daily life and in research activities. The universal motor can be used as a prime mover generator PMSG (Permanent Magnet Synchronous Generator), which in its application there is an obstacle that is difficult to stabilize the speed due to the influence of changes in the load connected to the PMSG, this affects the output voltage produced by the generator. In this case, a speed stabilizing system is required to stabilize the output voltage generated based on the load given to the system. AC Chopper is one of the circuits that can be applied in a speed control system that serves as an AC-AC voltage regulator that becomes a Universal motor input. Synchronous AC Chopper is one type of AC Chopper circuit which according to P.Sravan Kumar, in his research entitled Design and Implementation of AC Chopper (2014) that has been done before has a better performance in terms of efficiency than Basic AC Chopper. As for this control system, fuzzy logic is flexible and has a tolerance to existing data. Obtained data from the control that has a settling time of ± 15 second and average efficiency of 84.99%.

Keywords

Prime mover, PMSG, Synchronous, AC Chopper

INTRODUCTION

Universal motors are a commonly used type of motor and are easy to operate. This type of motor can work by using both AC and DC input voltages that facilitate its operation. The motor generally has a manual speed control system which is the default device of the motor, but manually operated controls have drawbacks if applied in research activities[1]. In research activities, Universal Motor is often used as a prime mover or drive from generators such as PMSG (Permanent Magnet Synchronous Generator). The character of PMSG that has a change in speed as the load value changes become an obstacle in speed control, therefore an automatic control system is required to stabilize the speed of PMSG driven using Universal motors.

AC Chopper is a circuit that can be applied in a controlling system that serves to regulate the voltage of the AC that becomes the input of the Universal motor. The type of AC Chopper used is Synchronous AC Chopper which has better performance than Basic AC Chopper[2], while for speed stabilization is done using Fuzzy Mamdani control which has the advantage of being intuitive and commonly used[3],[4].

The purpose of this study was to build a system that regulates AC input voltage with changes in PMSG speed that are affected by load values. The speed will be stabilized by Fuzzy control by using an optical encoder sensor as control feedback on the system.

RELATED THEORY

1. IGBT

Insulated Gate Bipolar Transistor (IGBT) is a semiconductor component equivalent to a combined BJT and a MOSFET. The IGBT input terminal has a very high impedance value, so it does not overload its control circuit which generally consists of logic circuits[5].

Input from IGBT is the Gateway terminal of MOSFET, while the Source terminal of MOSFET is connected to the Base terminal of BJT. Thus, the spout current out and from the MOSFET will be the base current of the BJT.

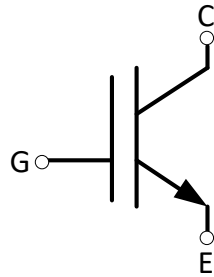

Figure 1. IGBT symbol

2. Rotary Encoder

A rotary encoder is an electromechanical device that can monitor movement and position. Rotary encoders generally use optical sensors to generate serial pulses that can be interpreted into movement, position, and direction. So that the angular position of a rotating object shaft can be processed into information in the form of digital code by the rotary encoder to be passed on by a series of controls[6].

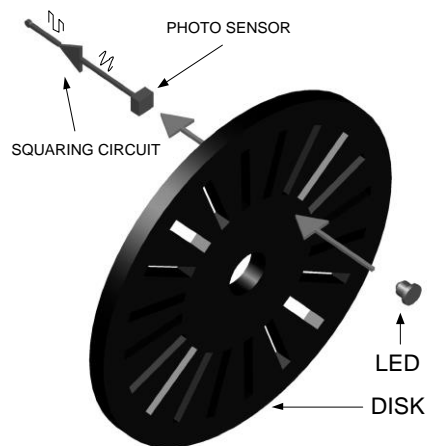

Figure 2. Rotary encoder working principle

The rotary encoder is composed of a thin disc that has holes in the circle of the disc. The LED is placed on one side of the disc so that the light will go to the disc. On the other hand, a photo-transistor is placed so that it can detect light from the opposing LED. The thin disc was moped with the shaft of the motor, or another rotating device that we want to know its position so that when the motor rotates the disc will also come spinning.

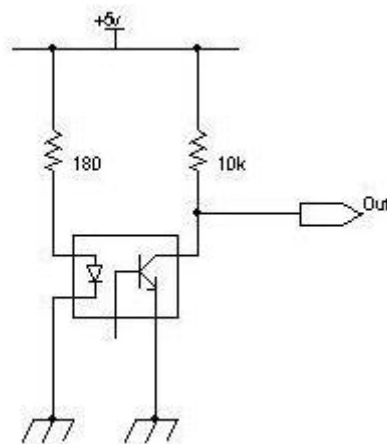

Figure 3. Typical pulse-producing circuits in rotary encoders

3. Motor Universal

The Universal motor is a series motor capable of working using both AC input voltage and DC input voltage. Setting the universal starting motor can be done by adjusting the input voltage on the universal motor.

To produce alternating voltages and varied unidirectional voltages for the universal motor power supply there are several alternatives such as using ac circuits or DC controlled or uncontrolled AC or DC circuits[1].

Power output (in horsepower) the motor is sent to the load is defined as:

$$P_{out, hp} = \frac{1.4 \cdot \omega_{rpm} \cdot T_{nm}}{10000} \quad (1)$$

where rpm is the speed of the motor in revolution per minute, TNM is torque in Newton – meters. Motor efficiency are:

$$efficiency = \frac{P_{out,w}}{P} \cdot 100\% \quad (2)$$

Where $P_{out,w}$ is the output power delivered to the load in Watts. Motor losses, therefore, are estimated as:

$$Losses = P - P_{out,w} \quad (3)$$

4. Pulse Width Modulation (PWM)

Sinusoidal Pulse Width Modulation is a technique of dissolving by comparing triangular waves and sine waves, with triangular waves as carriers and sine waves as modulated waves[7].

The working principle of one-phase SPWM signal generation is to regulate the pulse width following the sinusoidal wave pattern. The frequency of the reference signal determines the frequency of the inverter output. To find out the frequency modulation ratio of SPWM generation can be calculated by the equation:

$$M_f = \frac{f_c}{f_m} \quad (4)$$

Where, M_f = Modulation Ratio

f_c = Triangular Wave Frequency

f_m = Sine Wave Frequency

$$M_a = \frac{A_c}{A_m} \quad (5)$$

Where, M_a = Amplitude Modulation Ratio

A_c = Triangular Wave Amplitude

A_m = Sine Wave Amplitude

5. Synchronous AC Chopper

AC Chopper is a series of power electronics that have the function to convert AC to AC which uses variations of voltage to traverse loads with a fixed frequency. In phase control, this circuit uses two silicon-controlled rectifiers (SCR) or TRIAC. As for on-off control using switches with full control such as Thyristor Gate Turn-off, Power Transistor, Insulated Gate Bipolar Transistor, and MOS-Controlled Thyristor[8].

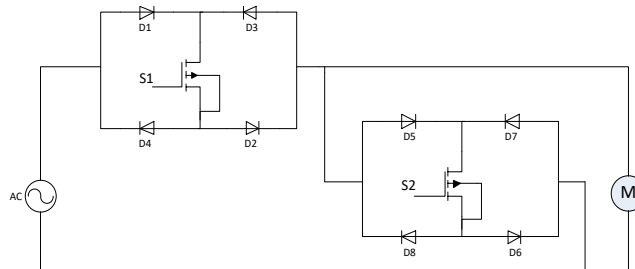

Figure 4. Synchronous AC Chopper circuit

In the circuit, the input voltage at the time of the cycle half a positive wave will pass through D1 which will pass through the S1 which is ON, and then flows on D3. When the switch 1 condition OFF, the positive wave will pass through D5 which will then be flowed to D7 by S2 which is in ON condition. In a negative input signal state, the source current will flow towards D2 which is passed to D4 by the S1 switch. When the S2 ON the current will pass through D6 and then towards D8.

6. Fuzzy Logic Control

Fuzzy is a set concept first developed by Zadeh in 1965. Although the concept of the fuzzy set was developed in the Americas, the use of fuzzy was most widely adapted and developed in Japan to be applied to control systems or artificial intelligence systems. Fuzzy logic has a way of working based on linguistic rules commonly used by humans or more specifically similar to instructions derived from an operator in performing control[3], [4].

Fuzzy logic controls have stages that must meet the 4 basic elements of Fuzzy logic, namely:

- a. Fuzzification

Contains mapping stages from members of the set firmly into fuzzy sets. Contains linguistic rules aimed at making fuzzy calculation easier.

b. Fuzzy rules/operators

Contains rules used in Fuzzy logic, which is an if-then rule. The proposition used is a type of compound proposition that can be represented as follows.

$$IF x_1 is A_1^k OR A_2^k \dots THEN y^k is B^k \quad (6)$$

c. Fuzzy Inference

Fuzzy inference is an evaluation stage on fuzzy rules that is done based on reasoning by using fuzzy rule input so that the output is obtained in the form of a fuzzy set. The method used is Mamdani inference method.

$$\mu_{B^k}(y) = \max[\mu_{A_1^k}(x_i), \mu_{A_2^k}(x_j)]_k \quad (7)$$

d. Defuzzification

It is the process of mapping the fuzzy set (B) to the set expressly as a continuous output, with the method used is centroid which is defined as follows.

$$Z^* = \frac{\int \mu_B(x).xdx}{\int \mu_B(x)dx} \quad (8)$$

In fuzzy logic control system designed to have two inputs, namely error value and delta error is defined by formula:

$$Error = PV - SP \quad (9)$$

$$DError = Error(n) - Error(n - 1) \quad (10)$$

where:

PV = Process Variable

SP = Set Point

PROCEDURE

A. System Design

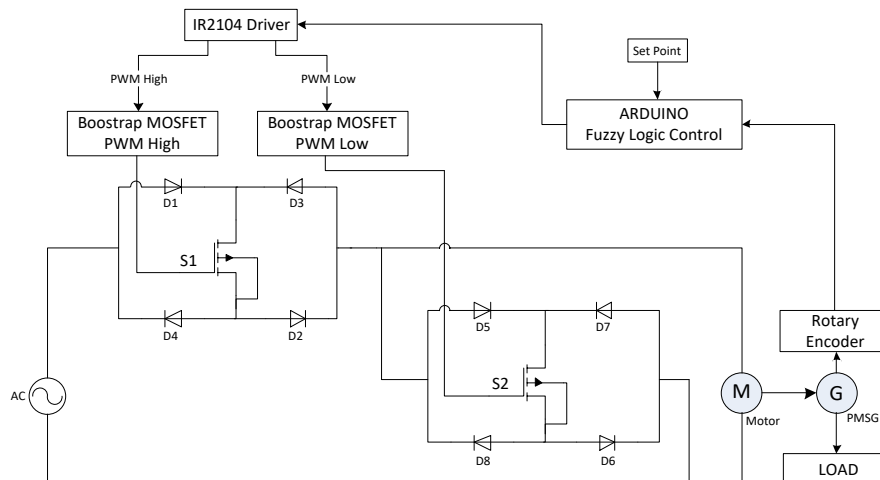

Figure 5. System Block Diagram

Figure 6 shows a block diagram depicting the entire working system of universal speed control motor design with Synchronous AC Chopper using Fuzzy Logic. This study aims to design a motor speed regulator for speed control at PMSG rpm resulting in generator rotation speed as expected. This study focused on setting PWM to produce a stable speed that matches the setpoint when connecting with the load. The reference speed is 1000 RPM which produces an output voltage value of 72.56 Volts.

- **Driver IR2104**

Consists of two capacitors, a diode, 2 resistors, and an IR2104 IC. This driver is connected with an input voltage of 12V. This driver serves to generate a synchronous PWM signal from Arduino with a signal output value of 5V.

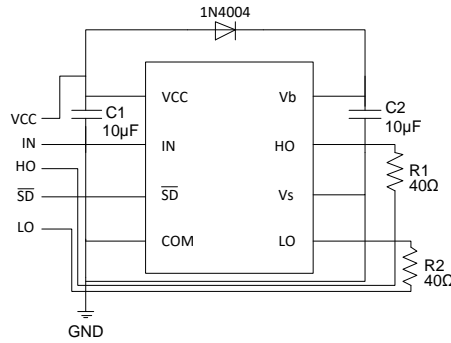

Figure 6. Circuit Schematic Driver IR2104

• **Bootstrap MOSFET**

The bootstrap circuit consists of seven resistors and four BC547-type transistors, connected to a DC 12V voltage source. The bootstrap circuit serves to increase the PWM signal voltage of the Arduino by 5V to 18V and is passed to the MOSFET on the Chopper AC circuit.

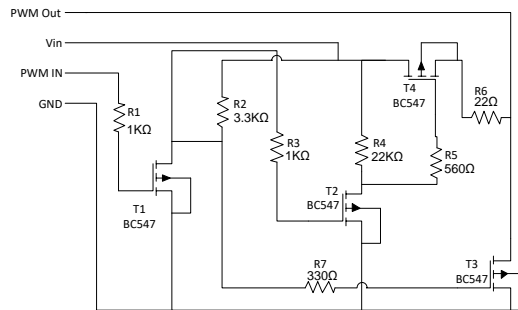

Figure 7. Circuit Schematic Bootstrap MOSFET

• **Synchronous AC Chopper**

AC Chopper series consists of 8 diode rectifiers with type Ultra Fast Recovery Diodes type HER307 which has a maximum voltage of 600 V and maximum current of 3.0 A and two MOSFET IGBT FGH60N60 with a maximum VDS of 600 V and VGS 20 V as a PWM signal switching that will regulate the output voltage.

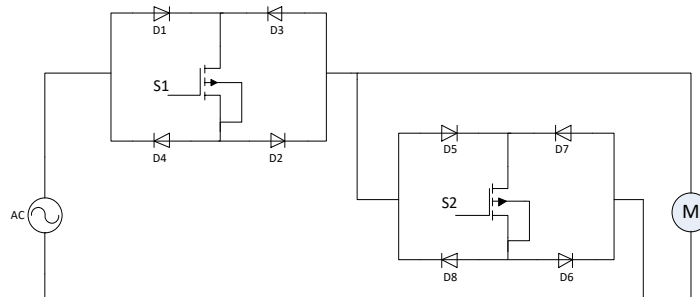

Figure 8. Circuit Schematic Synchronous AC Chopper

TABLE I
Synchronous AC Chopper Specs

| Synchronous AC Chopper Specs | | |
|------------------------------|------------|------------|
| Parameters | Symbol | Setpoint |
| Input voltage | V_{in} | 135 Volt |
| Load current | I_{load} | 0,5 Ampere |
| Frequency of switching | f_{sw} | 244 Hz |

B. Fuzzy Logic Control Method

In this study, a Fuzzy Logic controller is used in setting duty-cycle value in PWM as input switching to get the desired voltage output value.

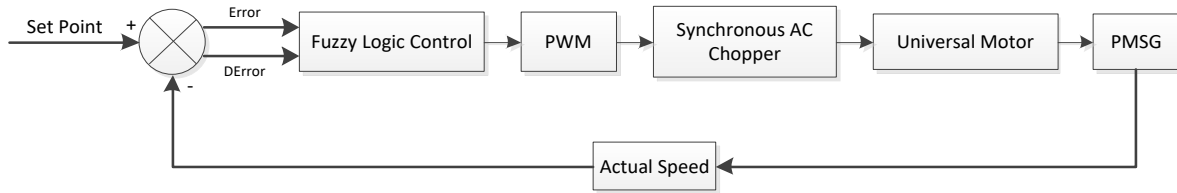

Figure 9. Fuzzy Logic Control Diagram Block

Based on figure 9 the system is created using 2 inputs and 1 output. Setpoints that are target speeds representing 1000 rpm speeds that will be processed by the Fuzzy Logic Control program. The Fuzzy control program will generate PWM values according to the Error and Delta Error inputs obtained. The resulting PWM will set the voltage intersection value that will be the Universal motor input. The Universal motor will drive the PMSG whose speed will be read by the rotary encoder and become feedback control on the system. The system will continue to work until PMSG speed matches the Set Point value.

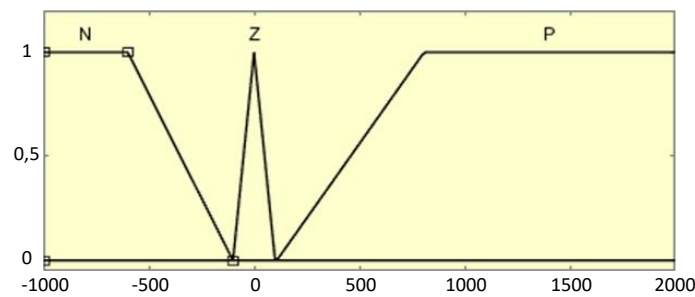

Figure 10. Error Membership Function

The initial stage is to determine the membership set members for Error inputs consisting of sets, N (Negative), Z (Zero), and P (Positive), with parameters N [-1000, -1000, -600, -100], Z values [-100, 0, 0, 100], and P [100, 800, 2000, 2000].

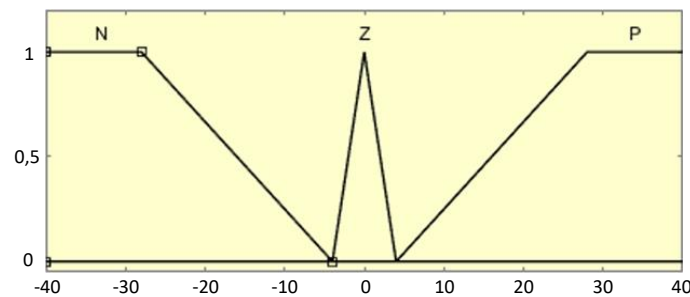

Figure 11. DError Membership Function

Membership for Derror values of the same set type as the N parameters [-40, -40, -28, -4], Z values [-4, 0, 0, 4], and P values [4, 28, 40, 40].

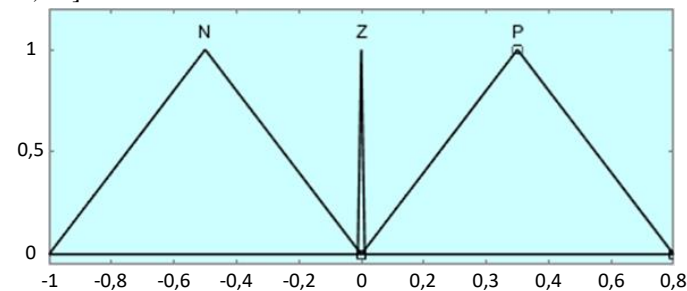

Figure 12. Dutycycle Membership Function

Next is the Output value which is the Duty cycle value in the fuzzy logic control system. The duty cycle membership function has a range [-1 1] which is the range of duty cycle output to be generated, with the set of N

having parameters [-1, -0.5, -0.5, 0], Z values [0, 0, 0, 0], and P values [0, 0.5, 0.5, 1]. Duty cycle output results are obtained based on a comparison of error and Derror inputs. The result of duty cycle output can be represented through the following rule base table:

TABLE II
Rule Base Data

| Error/Derror | N | Z | P |
|--------------|---|---|---|
| N | P | P | N |
| Z | P | Z | N |
| P | P | N | N |

From the table can be seen the output results of the fuzzy program created, which the output result is the result of a comparison of the two inputs that will be duty-cycle numbers based on the values of the membership function created.

RESULT

1. IR2104 Driver Testing

Testing in this circuit is to find out 2 PWM signals generated after synchronizing or splitting 1 signal into 2 PWM signals that are synchronous from the microcontroller. In this circuit, the resulting PWM voltage value has the same voltage as the signal result of the microcontroller which is 5V. Sampling has a Duty-cycle value range of 7%-94% displayed on the Oscilloscope. Here are the test results of the IR2104 driver set.

TABLE III
IR2104 Driver Circuit Testing Data

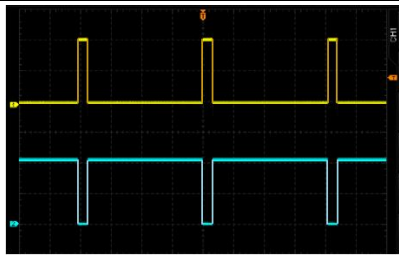
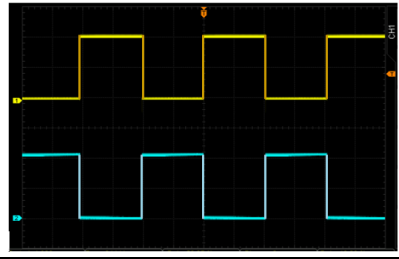
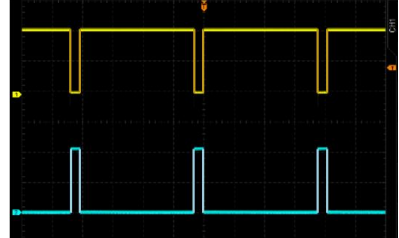
| No. | PWM signal wave | Information |
|-----|---|--|
| 1. |  | Frequency = 244 Hz T = 4 ms <i>Dutycycle 7%</i> |
| 2. |  | Frequency = 244 Hz T = 4 ms <i>Dutycycle 50%</i> |
| 3. |  | Frequency = 244 Hz T = 4 ms <i>Dutycycle 94%</i> |

From Table III it can be known that PWM signals are raised from microcontrollers at PWM values of 20-240 or duty-cycle 20%-94% are synchronous. The frequency value on PWM signals generated from Arduino microcontrollers and at bootstrap circuit output is 244 Hz.

2. Bootstrap MOSFET Circuit Testing

This circuit test aims to be able to know the PWM signal that has been increased voltage that was originally 5V from ir2104 driver to 20V. Testing was conducted by looking at the PWM signal waves coming out of this circuit. PWM signals are displayed using an oscilloscope with Rigol type DS1054. Here are the test results of the MOSFET bootstrap driver set.

TABLE IV
Bootstrap MOSFET Circuit Testing Data

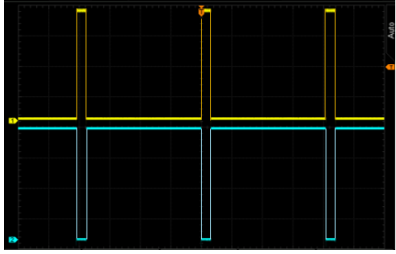
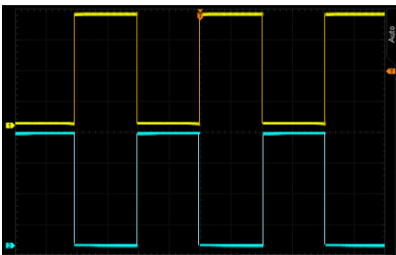
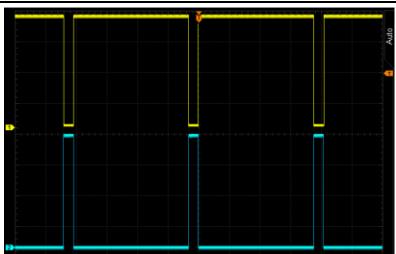
| No. | PWM signal wave | Information |
|-----|--|--|
| 1. |  | Frequency = 244 Hz T = 4 ms Duty cycle 7% |
| 2. |  | Frekuensi = 244 Hz T = 4 ms Duty cycle 50% |
| 3. |  | Frekuensi = 244 Hz T = 4 ms Duty cycle 94% |

From Table IV it can be known that a PWM signal is raised from the MOSFET bootstrap driver circuit at a PWM value of 20 or a duty-cycle of 7% to a PWM value of 240 or a duty-cycle of 94%. In this circuit, the synchronous PWM signal of the IR2104 driver with a voltage of 5V is increased to 20V.

3. AC Chopper Circuit Testing

Testing aims to determine the error of the AC Chopper device with and know the amount of alternating current voltage value that is trimmed using this circuit. This test was conducted with duty-cycle variations of 7%, 50%, and 94% with three trials. Chopper AC devices use input voltages of 100V, 150V, and 220V set from AVR and with a lamp output of 15W as load. Here's the data from the Chopper AC circuit experiment.

TABLE V
Test Data 1 AC Chopper Circuit

| Duty cycle | Vin | Vout | Vout(Theory) | E% |
|------------|-------|--------|--------------|---------|
| 7,8% | 100 V | 48,6 V | 7,8 V | 83,95 % |
| 50% | 100 V | 70,5 V | 50 V | 29,07 % |
| 94% | 100 V | 98,4 V | 94 V | 4,47 % |

TABLE VI
Test Data 2 AC Chopper Circuit

| Duty cycle | Vin | Vout | Vout(Theory) | E% |
|------------|-------|---------|--------------|---------|
| 7,8% | 150 V | 98,7 V | 11,7 V | 76,99 % |
| 50% | 150 V | 128,3 V | 75 V | 38,43 % |
| 94% | 150 V | 140 V | 141 V | 0,85 % |

TABLE VII
Test Data 3 AC Chopper Circuit

| Duty cycle | V _{in} | V _{out} | V _{out} (Theory) | E% |
|------------|-----------------|------------------|---------------------------|---------|
| 7,8% | 220 V | 168,2 V | 17,68 V | 78,16 % |
| 50% | 220 V | 189,9 V | 110 V | 41,85 % |
| 94% | 220 V | 201,8 V | 206,8 V | 2,33 % |

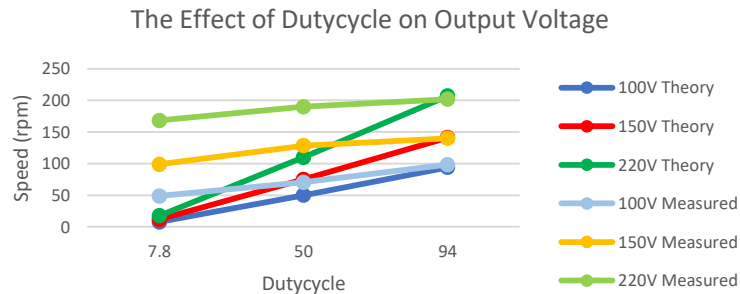

Figure 13. Graph of The Effect of *Duty cycle* on *Output Voltage*

From figure 13 it can be known that when the duty-cycle value given is greater it will result in a small difference between V_{out} and $V_{out}(\text{theory})$. From table V to Table VII, it is also known that the average error value is 40.7%, with the smallest error value of 0.8% and the largest at 83.95%. Three tests with three types of input voltages namely 100 V, 150 V, and 220 V using 15 W lamp as load obtained also range value from trimming the average voltage of 51.74 V.

4. Sensor Calibration and Testing

The sensor used to read the speed of the universal motor is the LM393 Optical Encoder sensor placed on the motor output. Calibration and sensor testing are performed to regulate the sensor to produce data that has a high level of accuracy and precision with measurement reference from the tachometer. The test was conducted 10 times by comparing sensor measurements with measurements using tachometers in conditions 5 times without load and 5 times with load. The load used by the motor is a permanent magnet Synchron generator.

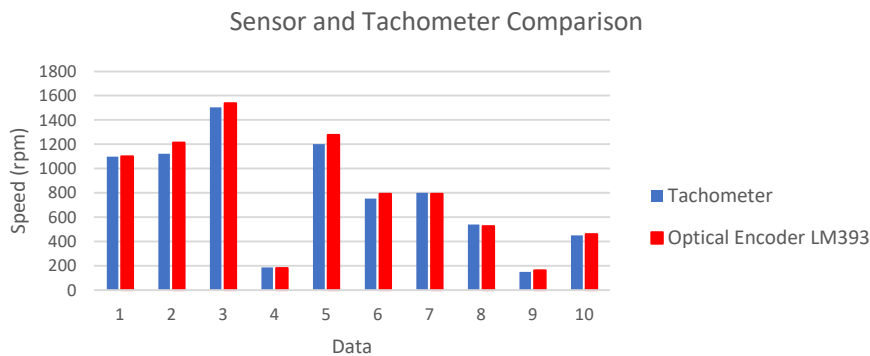

Figure 14. Tachometer Sensor Readings and Tachometer Comparison Graph

Out of the 10 test samples obtained an average error value of 3.89% with the smallest error value of 0.18% and the largest 8.11%. Based on the average error value obtained, it can be concluded that the LM393 optical encoder sensor has a reading with good precision.

5. Overall System Analysis and Testing

Testing was conducted by testing an overall system that works by controlling motor speed with a stable universal motor speed target at 1000 RPM with load-free and unburdened conditions. The load used is the Permanent Magnet Synchron Generator connected with a 15W lamp.

• Universal Driver Testing Without Load

Testing was conducted by connecting the Synchronous AC Chopper circuit with a universal motor without being connected to the load. The input voltage used by universal motor drivers is 135 V with a set point duty-cycle starting at 50% and will change as Error and Derror change on the Fuzzy Logic Controller. Here's the universal motor driver testing data without load:

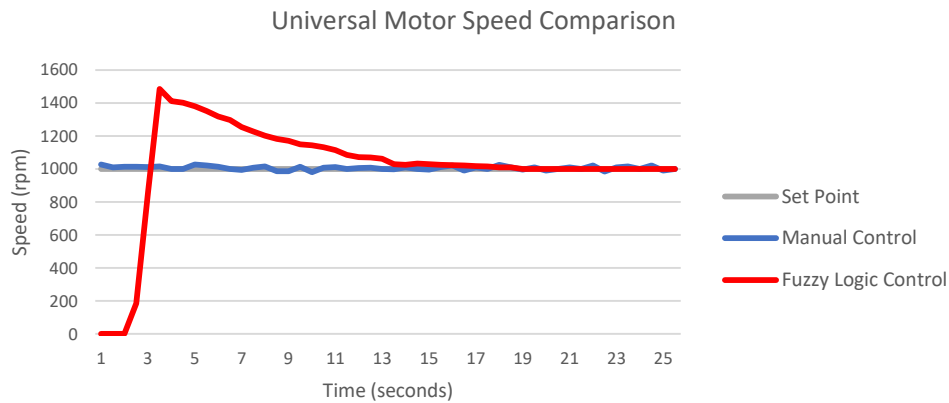

Figure 15. Universal Motor Comparison Graph with Manual Control and Fuzzy Logic Control

Based on figure 15, it can be seen that with a voltage of V_{in} 135 V control Fuzzy can produce a duty-cycle value suitable for motor speed with a range of 1000 RPM which in this case has an initial duty-cycle value of 50% and produces a duty-cycle of 9% with a driver output voltage of 111.12 V.

- **Universal Motor Driver Testing With Load**

This test uses the same input voltage of 135V with the same set-point duty-cycle of 50%. The load used is a permanent magnet Synchron generator.

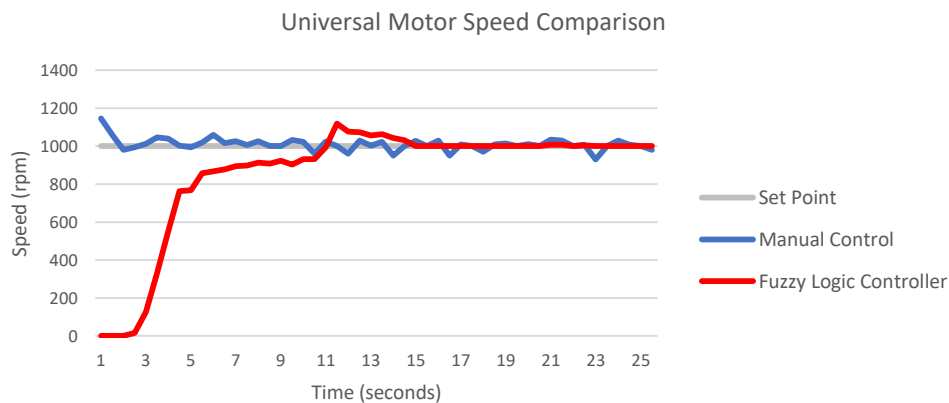

Figure 16. Universal Motor Comparison Graph with Manual Control and Control

Based on figure 16, it can be seen that with the same V_{in} on the driver of 135 V and with the same set-point Duty cycle 50% of the resulting chart characteristics are different, i.e. the change in motor speed at the initial output tends to be close to the setpoint speed value slowly and with minimal overshoot. The wave characteristics that use Fuzzy Logic Control tend to be more stable, namely reaching a speed of 1000 RPM at a duty-cycle range of 88%-90% and with a driver output voltage value of 128.12 V.

- **Analysis and Overall Motor Driver Testing**

The last test was conducted by providing two conditions on the system, namely the condition of burdened and unburdened. The generator is connected with a resistor load of $8.4K\Omega$ 14Watt as an unburdened condition and a 15Watt/220Volt lamp as a weighted condition. The system is tested by giving these two conditions alternately 5 times in a row. Here is the data of the test results that have been done:

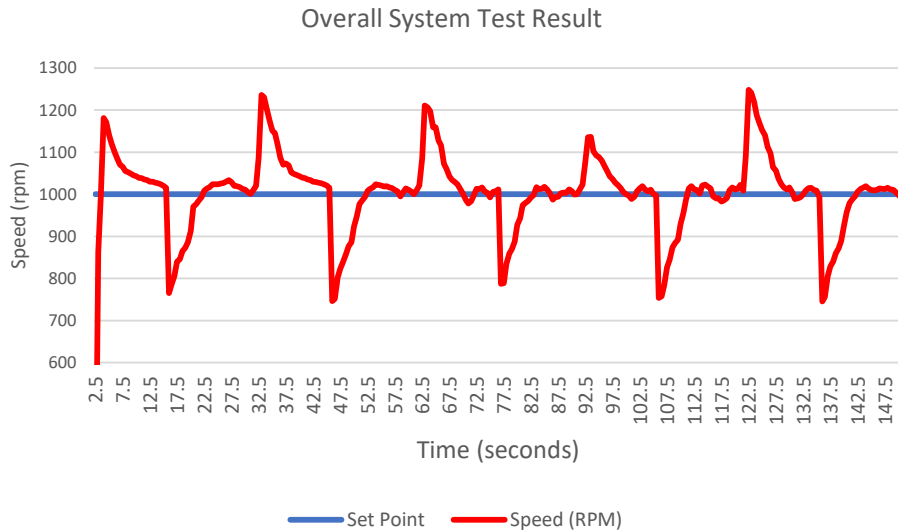

Figure 17. Universal Motor *Driver* Testing Graph

From the test known drop the lowest speed is worth 745.18 RPM and the highest overshoot speed is worth 1247.97 RPM, and also known duty-cycle value produced is 9% at the lowest value and 93% at the highest value. From this test, it is also known that the speed of 1000 RPM produces a generator output voltage of 152 Volts.

In table 4.13 can be known the test results of both conditions. In no-load conditions, the system reaches a speed of 1005.08 RPM or zero conditions at a duty-cycle value of 9% with a V_{out} Synchronous AC Chopper value of 111.42 Volts. In load conditions, the system reaches a speed of 1005.16 RPM (Zero) on a duty-cycle of 93% with a V_{out} Synchronous AC Chopper value of 128.13 Volts. Both conditions take ± 15 seconds to reach 1000 RPM or zero conditions, this can be known based on the program's 500 ms delay value which means 0.5 seconds for every single data that a serial monitor appears.

CONCLUSION

The system is built using the main Switching component in the form of IR2104 IC that serves to break the PWM wave into synchronous waves which are further strengthened using Bootstrap Mosfet Driver and then entered as PWM input on synchronous AC Chopper series with IGBT transistor type with FGH60N60 type. Synchronous AC Chopper is capable of producing an AC input voltage intersection of 135 V with an intersection range of 24 V from the resulting duty cycle output. Furthermore, the entire control system is connected with the fuzzy logic feedback control that has been created. The control system that has been created is then connected with the Universal Motor. Universal motor speed control in the state of voltage addition or release takes 14-15 seconds to achieve a steady-state of 1000 rpm speed, known from the delay value of 500 ms on the serial monitor with a speed of 1000 rpm at the data reading to 30.

REFERENCES

- [1] I Gede Nurhayata, "Sistem Pengaturan Kecepatan Motor Universal Satu Fasa Dengan Metode Kontrol Sudut Fasa Berbasis Mikrokontroler AT89S52," *JPTK*, vol. 12, pp. 75–88, 2015.
- [2] P. Sravan Kumar and M. Shruthi, "Design and Implementation of AC Chopper," 2014. [Online]. Available: www.ijeert.org
- [3] H. M. Himawan, O. Setyawati, and H. Suyono, "Pemodelan Fuzzy Logic Control untuk Pengendali PWM pada Buck Converter," 2016.
- [4] D. Vinsensia, "Study Tentang Aplikasi Fuzzy Logic Mamdani Dalam Penentuan Prestasi Belajar Siswa (Study Kasus: Smp Pembangunan Nasional Pagar Merbau)," *Jurnal Mantik Penusa*, vol. 18, no. 2, 2015.
- [5] Y. E. Prasetyo and F. Rohman, "Analisis Perbandingan Kinerja H-Bridge Driver Menggunakan Igbt Dan Mosfet Pada Sistem Kemudi Steer By Wire," *Jurnal Ilmiah Ilmu-Ilmu Teknik*, vol. 3, no. 1, pp. 73–80, 2018.

- [6] M. Amin, J. Triyanto, and Sukandar, "Antar Muka Quadrature Rotary Encoder Pada STM32F407VGT6 BRAKITERAPI HDR IR-192 Menggunakan Modul LS7184N," *PRIMA*, vol. 16, no. 2, pp. 24–32, 2019.
- [7] D. Setiawan, "Sistem Kontrol Motor Dc Menggunakan Pwm Arduino Berbasis Android System," *Jurnal Sains, Teknologi dan Industri*, vol. 15, no. 1, pp. 7–14, 2017.
- [8] S. Laila Luthfiani and Krismadinata, "Rancang Bangun AC to AC Converter Tiga Fasa dengan Visual Basic," *JTEV*, vol. 6, no. 2, pp. 152–167, 2020, [Online]. Available: <http://ejournal.unp.ac.id/index.php/jtev/index>