

## **The Influence of #RacunTikTok Trends, Customer Review and Customer Rating on Purchase Decisions through Purchase Intention**

Syaiful Arifin\*, Sela Setyorini

Faculty of Economics and Business, University of Merdeka Malang, Indonesia

Corresponding email: [syaiful.arifin@unmer.ac.id](mailto:syaiful.arifin@unmer.ac.id)

**Abstract:** This study aims to analyze the influence of #RacunTikTok hashtag trends, online customer reviews, and online customer ratings on online purchase intention. The research used quantitative data analysis using structural equation modeling with IBM-SPSS-AMOS. The data were provided in Google Forms and distributed online to university students who had watched the hashtag video #RacunTikTok and had made purchases at marketplace TikTok. The results of data analysis show that hashtag trends #RacunTikTok, online customer reviews, and online customer ratings have a positive and significant effect on online purchase intention. Trends in the hashtag #RacunTikTok, online customer reviews, and online customer ratings have a positive and significant impact on purchasing decisions in the TikTok shop marketplace. Indeed, online purchase intention affects purchasing decisions in the TikTok marketplace. Finally, trends in the hashtag #RacunTikTok, online customer reviews, and online customer ratings have no effect on purchasing decisions through online purchase intention in the TikTok marketplace for the University of Merdeka Malang students.

**Keywords:** #RacunTikTok Hashtag Trend, Online Customer Review, Online Customer Rating, Online Purchase Intention, Purchase Decision

### **INTRODUCTION**

The rapid development of the digital era, both in the field of communication and the internet, has brought changes in everyday life. Social media itself is part of the development of the technological era and functions as a means of communication that has been embedded in social circles, especially among students. Social media not only has a big influence but also has an impact on the formation of behavior patterns, such as people's lifestyles, that are experiencing a shift. This change can also be seen in the habits of people who prefer to shop online at marketplaces rather than having to shop offline or directly at stores. According to Wibowo and Haryokusumo (2020), digital marketing trends and online shopping are opportunities for manufacturers in the era of the industrial revolution 4.0.

Extensive and unlimited communication between users creates opportunities for buying and selling transactions. Changes in people's behavior patterns that follow technological developments that are centered on community needs are known as Society 5.0. This era makes it easy for humans to meet their needs. In Indonesia itself, various kinds of companies have spread widely that offer online-based goods and services (Mumtaha & Khoiri, 2019). This phenomenon affects social media users competing in buying and selling transactions on the marketplace. More and more consumers are switching to online transactions because they are

more effective and efficient, making startups start to flood the market using the marketplace, which they feel is more profitable compared to the old sales system.

One of the platforms used as an intermediary for online buying and selling activities is TikTok. TikTok is an application that is commonly used as a talent channel, in the form of short videos equipped with attractive filters that are easy to operate by simply scrolling the screen on a smartphone. Manurung et al. (2022) noted that TikTok was launched by the Chinese state in September 2016. The number of TikTok users has jumped since the 2020 pandemic, and almost all countries have implemented quarantine policies. The following is the number of global TikTok users per second quarter of 2018–2nd quarter of 2022. According to the datadoks by Annur (2022), the number of TikTok users continues to increase every month. TikTok had 1.46 billion active users per month in the second quarter of 2022. This number has increased by 62.52% compared to the second quarter of 2021, when the number of active users was only 564 million.

TikTok's success in building its image again has an effect on its increasing market share, giving TikTok opportunities to develop its business through an online shopping feature known as the TikTok Shop. This feature allows users to make buying and selling transactions online, like in e-commerce in general, without having to bother accessing the marketplace again to make transactions. Users can also see products being sold or promoted on TikTok's video content by selecting the "yellow basket" image in the lower left corner. TikTok's video content can be accessed directly on the main menu section of TikTok, which is commonly referred to as FYP (For Your Page), which is the main page of the TikTok application and contains content such as dance challenges, educational content, tutorial content, "a day in my life" content, content promotions, product unboxing content, product review content, and TikTok "poison" content.

The term of poison refers to a trend that contains informational video content, recommendations, unboxing videos, and video reviews about a product that is cute, aesthetic, multifunctional, and unique. Make the audience influenced and interested in buying the product. This content category is grouped under the hashtag #racunTikTok to make it easier for users to search for the same topic. This content is also used by users who have businesses to offer their products through this hashtag trend. The hashtag #poison TikTok has racked up 9.6 billion views. The videos in this content discuss various kinds of products, such as modern outfits, skincare, electronic devices, makeup, interesting tourist spots, and food.

Content creators make videos with the hashtag #RacunTikTok as attractive as possible with the aim of the video being included in the FYP so that it can reach a global audience. The trend of the hashtag #racunTikTok has had a beneficial impact on sellers, with their viral product videos trying to attract the attention of many buyers so that they are exposed to "TikTok poison" and end up being flooded with orders. Consumer evaluation when making a purchase decision can be seen from several other influencing factors. Among them are online customer reviews. According to Daulay (2020), an online customer review is a measuring tool for product quality, delivery time, service, and so forth. Online customer reviews as a consideration tool for other consumers in making purchasing decisions, as well as assisting sellers in improving the quality of their products and services.

Another factor that influences the purchase decision is the online customer rating. According to Saskiana (2021), online customer rating is a reference value given by customers based on satisfaction with the shopping experience as measured using a star scale. The star scale used is from one star to five stars. One star means a very bad rating that is usually given by customers when disappointed because the product does not meet expectations. Five stars are the best rating, given when the customer is satisfied with the product purchased. The following is an example of an image on the online customer rating feature. With the hashtag #racuntiktok content, online customer reviews, and online customer ratings, it will revive the online purchase intentions of other customers and determine purchasing decisions on online marketplaces. Therefore, online customers only rely on product descriptions provided by sellers and reviews and ratings from other customers.

This research is motivated by research gaps in previous studies. Based on research conducted by Manurung et al. (2022) that the message content of TikTok's toxic content has no effect on purchasing decisions in the Prefix Community, while the attractiveness of content has an effect on purchasing decisions in the Prefix Community. However, Rachmawati (2021) noted that the #RacunTikTok persuasion influences the consumptive behavior. Furthermore, research online customer reviews and online customer ratings. Sari (2021) that customer reviews and customer ratings simultaneously have a positive and significant influence on online purchasing decisions in e-commerce for UMSU students. In addition, Saskiana (2021) that online customer reviews have no significant effect on buying decisions for Shopee marketplace consumers in Surabaya, but online customer ratings have a significant effect on buying decisions for Shopee consumers in Surabaya.

Another study conducted by Daulay (2020) showed that online customer ratings have a dominant influence on purchasing decisions because consumers are aware of the benefits of the rating feature, so consumers in the Shopee marketplace have a high level of satisfaction. However, it is different from Hariyanto and Trisunarno (2021) that the review feature has a more dominant influence compared to the rating feature. Some studies (e.g., Gabriela & Mulyandi, 2022; Harli et al., 2021; Mawa & Cahyadi, 2021) found that online customer reviews and online customer ratings have an effect on purchase intention. While other studies (e.g., Anuang and Korry, 2020; Solihin, 2020) reported that buying interest influences purchasing decisions. This study aims to analyze the influence of #RacunTikTok hashtag trends, online customer reviews, and online customer ratings on online purchase intention, the influence of #RacunTikTok hashtag trends, online customer reviews, and online customer ratings on purchase decisions, and the effect of online purchase intention on decisions. Purchasing, analyzing the influence of #RacunTikTok hashtag trends, online customer reviews, and online customer ratings on purchase decisions through online purchase intention for the University of Merdeka Malang students.

## METHODS

### Population and Sampling Techniques

The population used in this study were all active students at the University of Merdeka Malang, totaling 9,476 students. The reason the researcher chose the

student population is because students are very closely related to social media and like to transact on online marketplaces, including the TikTok application. Table 1 provides information about the number of active students at the University of Merdeka Malang for the 2019–2022 class.

**Table 1.** The student population at the University of Merdeka Malang

<b>Faculty</b>	<b>Number of Students</b>
Faculty of Economics and Business	2,820
Faculty of Law	1,241
Faculty of Psychology	981
Faculty of Engineering	1,304
Faculty of Social & Political Sciences	1,701
Faculty of Information Technology	922
Faculty of Tourism	507
<b>Total</b>	<b>9,476</b>

The number of samples in this study was calculated using the Slovin formula. Based on the results of the calculations, the sample used as respondents for this study was adjusted to 175 students. The sample used is a non-probability sampling technique, namely the researcher does not provide equal opportunities for each member of the population selected to be the sample. Sampling was carried out using a purposive sampling technique because researchers have their own considerations in selecting members of the population, where respondents as data sources must meet the criteria, namely active students at the University of Merdeka Malang who have the TikTok application, have watched the hashtag video #RacunTikTok, and have made purchases at the marketplace TikTok.

### **Measurement**

The hashtag indicator #RacunTikTok was adopted from Rachmawati (2021), including: perceptions of the TikTok application, creator content, and interest in goods. Online customer reviews are measured by indicators adopted from Rinaja et al. (2022) which consist of source credibility, quality arguments, perceived usefulness, review valence, and quantity of reviews. Online customer rating indicators were adopted from Priangga and Munawar (2021), which cover perceived usefulness, perceived enjoyment, and perceived control. Online purchase intention uses indicators adopted from Ferdinand (2002), including transactional interest, reference interest, preference interest, and explorative interest. According to Melati and Dwijayanti (2020), the indicators for purchasing decisions are as follows: choice of product, choice of brand, choice of seller, number of products purchased, time needed to buy the product, and method of payment.

### **Data Collections**

Questionnaires were distributed on 1 – 7 February 2023 via Google form to respondents who were accompanied by technical instructions for filling out the questionnaire, with a respondent rate of 98%. The completed questionnaires were then collected for processing.

### Data Analysis

To measure the validity of the questionnaire given to the respondents, confirmatory factor analysis (CFA) was used. The validity of an indicator can be declared valid if the indicator used can measure a particular construct when the critical ratio (CR) of the regression weight shows a value above 2.0 with a p-value less than 0.05. A research instrument is declared reliable if the acceptable reliability threshold value is construct reliability  $> 0.7$ . While the reliability of 0.6–0.7 is still acceptable (Ghozali, 2018). Analysis of the research data used SEM (structural equation models) and AMOS 18 software to address the proposed research hypothesis.

## RESULTS AND DISCUSSION

### Characteristics of Respondents

The characteristics of the respondents in this study were the University of Merdeka Malang students who have the TikTok application, have watched the hashtag #RacunTikTok content, and have made purchases at the TikTok. In addition, it also represents a very large number of the population, so a sample of 175 respondents was determined. The characteristics of the respondents also explained their identity, which included faculties, study programs, year of class, and gender. Table 2 informs a general description of the respondent's identity. Based on Table 2, it can be seen that of the 175 respondents in this study, 44 (25.1%) students of the Faculty of Economics and Business were dominant, 32 (18.3%) undergraduate psychology study program students, and 106 female students (60.6%).

**Table 2.** Characteristics Respondents

Information	Frequency	Percentage (%)
<b>Faculty</b>		
Faculty of Economics and Business	44	25.1
Faculty of Law	23	13.1
Faculty of Psychology	32	18.3
Faculty of Engineering	30	17.1
Faculty of Social & Political Sciences	21	12.0
Faculty of Information Technology	14	8.0
Tourism Diploma	11	6.3
<b>Study program</b>		
S1 Management	27	15.4
S1 Accounting	11	6.3
S1 Development Economics	2	1.1
D3 Accounting	2	1.1
D3 Banking & Finance	2	1.1
S1 Law Science	23	13.1
S1 Psychology	32	18.3
S1 Civil Engineering	16	9.1
S1 Mechanical Engineering	8	4.6
S1 Architectural Engineering	1	.6
S1 Electrical Engineering	2	1.1
S1 Industrial Engineering	3	1.7
S1 Public Administration	7	4.0

S1 Business Administration	4	2.3
S1 Communication Studies	5	2.9
D3 English	5	2.9
S1 Information Systems	13	7.4
D3 Information Systems	1	.6
D4 Tourist Destinations	3	1.7
D3 Hospitality	6	3.4
D3 Tourism Travel	2	1.1
<b>Year of Study</b>		
2019	64	36.6
2020	39	22.3
2021	26	14.9
2022	46	26.3
<b>Gender</b>		
Man	69	39.4
Woman	106	60.6

**Normality Test**

Testing the normality of the data is provided by observing the value of the critical ratio in a multivariate manner. If the multivariate critical ratio value is within the range of -2.58 to 2.58, then the data distribution can be categorized as normal. Table 3 provides the results of the multivariate normality test in the structural model.

**Table 3.** Normality Test Results

Variable	Min	Max	Skew	C.R.	Kurtosis	C.R.
Y26	3.000	5.000	-0.085	-0.460	-0.139	-0.374
Y25	3.000	5.000	0.090	0.487	-0.090	-0.243
Y24	3.000	5.000	0.032	0.172	-0.063	-0.170
X25	3.000	5.000	0.043	0.230	-0.679	-1.834
X24	3.000	5.000	-0.165	-0.891	-0.307	-0.830
X23	3.000	5.000	-0.104	-0.563	-0.735	-1.986
X33	2.000	5.000	-0.671	-1.626	0.888	2.398
Y11	2.500	5.000	0.239	1.288	-0.948	-2.160
X22	3.000	5.000	-0.076	-0.411	-0.617	-1.665
X21	3.000	5.000	-0.052	-0.280	-0.659	-1.778
X32	2.500	5.000	-0.129	-0.697	-0.168	-0.453
X13	3.000	5.000	-0.006	-0.030	-0.363	-0.981
X31	2.000	5.000	-0.400	-2.162	0.101	0.272
Y12	3.000	5.000	0.198	1.070	-1.291	-2.485
Y13	2.500	5.000	0.047	0.254	-0.848	-2.289
Y14	2.500	5.000	0.012	0.062	-0.922	-2.490
Y23	3.000	5.000	-0.379	-2.045	-0.262	-0.707
Y22	2.500	5.000	0.091	0.490	-0.568	-1.534
X12	2.000	5.000	0.064	0.347	-0.745	-2.013
X11	3.000	5.000	-0.445	-2.404	-0.347	-0.937
Y21	2.500	5.000	-0.505	-1.729	0.585	1.579
Multivariate					42.385	2.020

Based on the results of data processing from Table 3, it is known that the multivariate critical ratio value is 2.020 which is between -2.58 to 2.58, so it is concluded that the multivariate normality assumption has been fulfilled, thus the normality assumption required by SEM analysis has been fulfilled.

### Confirmatory Factor Analysis

Confirmatory analysis of exogenous variables (#RacunTikTok trends, online customer reviews, and online customer ratings) was carried out to confirm whether the observed variables could reflect the factors being analyzed, namely having a model fit test – the goodness of fit test, significant factor weights and lambda or factor values loading.

**Table 4.** Confirmatory Factor Analysis Results for Exogenous Variables

Indicator	Latent Variable	Factor Loading	Critical Ratio	P-value	Information
Perceptions of the TikTok application Creator Content	#Racuntiktok Trends	0.646	Fixed	0.000	Valid
Interest in goods	#Racuntiktok Trends	0.574	5.805	0.000	Valid
Source Credibility	#Racuntiktok Trends	0.713	6.581	0.000	Valid
Argumen Quality	Online customer review	0.580	Fixed	0.000	Valid
Perceived Usefulness	Online customer review	0.605	6.069	0.000	Valid
Review Valence	Online customer review	0.760	6.971	0.000	Valid
Quantity of Reviews	Online customer review	0.662	6.443	0.000	Valid
Perceived Usefulness	Online customer rating	0.653	6.386	0.000	Valid
Perceived Enjoyment	Online customer rating	0.689	Fixed	0.000	Valid
Perceived Control	Online customer rating	0.606	6.219	0.000	Valid
Reliability Construct	= 0.941	(cut-off value = 0.7)			Reliable
Variance Extract	= 0.654	(cut-off value = 0.5)			Reliable

Based on the information in Table 4, it shows that the factor loading value for each indicator exceeds the cut-off value of 0.5, the probability value (p) is less than or equal to 0.05, the reliability construct value of 0.941 is greater than the cut-off value of 0.7 and the Variance Extract value of 0.654 is greater than the cut-off value of 0.5. The #Racuntiktok Trends indicator shows the highest factor loading value is Interest in goods with a value of 0.713, the Online customer review indicator shows the highest factor loading value is Perceived Usefulness with a value of 0.760, while the online customer rating indicator shows the highest factor loading value is Perceived Control with a value of 0.707. The results of this test indicate that the

tested indicators have good reliability in establishing and operating the latent variable #RacunTikTok Trends, online customer reviews, and online customer ratings.

**Table 5.** Results of Confirmatory Factor Analysis of Endogenous Variables

Indicator	Latent Variable	Factor Loading	Critical Ratio	P-value	Information
Transactional interest	Online purchase intention	0.808	9.366	0.000	Valid
Reference interest	Online purchase intention	0.651	7.769	0.000	Valid
Preference interest	Online purchase intention	0.774	9.071	0.000	Valid
Explorative interest	Online purchase intention	0.710	Fixed	0.000	Valid
Choice of products	Purchase Decisions	0.737	Fixed	0.000	Valid
Choice of brands	Purchase Decisions	0.659	8.233	0.000	Valid
Choice of seller	Purchase Decisions	0.607	7.567	0.000	Valid
Number of products purchased	Purchase Decisions	0.582	7.248	0.000	Valid
The time it takes to buy the product	Purchase Decisions	0.617	7.700	0.000	Valid
Payment method	Purchase Decisions	0.761	9.504	0.000	Valid
Reliability Construct	= 0.950	(cut-off value = 0.7)			Reliable
Variance Extract	= 0.691	(cut-off value = 0.5)			Reliable

Based on the information in Table 5, it shows that the factor loading value for each indicator exceeds the cut-off value of 0.5, the probability value (p) is less than or equal to 0.05, the reliability construct value of 0.950 is greater than the cut-off value of 0.7, and the variance extract value of 0.691 is greater than the cut-off value of 0.5. The online purchase intention indicator showing the highest factor loading value is transactional interest with a value of 0.808, while the purchase decision indicator showing the highest factor loading value is the payment method with a value of 0.761. The results of this test indicate that the indicators tested have good reliability in establishing and operationalizing the latent variables of online purchase intention and purchase decision.

### Results SEM Analysis

Based on the AMOS 20 results for this SEM model, the goodness of fit indices produced are presented in Table 3. Furthermore, these index values are compared with the critical value (cut-off value) of each index. A good model is expected to have goodness of fit indices that are greater than or equal to the critical value.



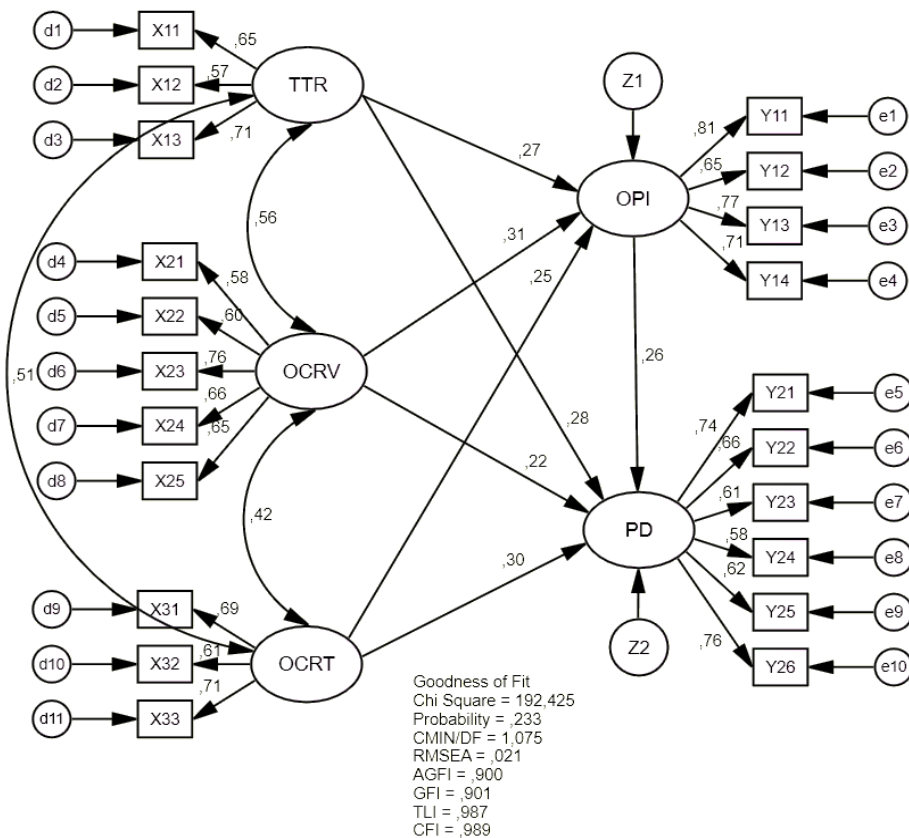

Figure 1. SEM Analysis Results

Table 6. Results of Structural Goodness of Fit Model Modification

Goodness of Fit Index	Cut-offs Value	Results Model	Information
Chi-Square (df = 179)	128.80	192.425	fit
Probability Chi-Square	≥ 0.05	0.233	fit
CMIN/DF	≤ 2.00	1.075	fit
RMSEA	≤ 0.08	0.021	fit
GFI	≥ 0.90	0.900	fit
AGFI	≥ 0.90	0.901	fit
CFI	≥ 0.95	0.987	fit
TLI	≥ 0.95	0.989	fit

Based on the results of the evaluation of the Goodness of Fit Indices criteria in Table 6, the results of the evaluation of the model as a whole have been fulfilled, so that the model can be accepted. Testing hypotheses in the study is provided by considering the p-value (probability), if the p-value is greater than or equal to 0.05, it is said that there is a significant influence, and vice versa.

Table 7 shows that the variable trend, the hashtag #RacunTiktok, has a p-value of 0.034, an online customer review of 0.006, and an online customer rating of 0.023 (<0.05), which means the trend hashtag #RacunTiktok, online customer reviews, and online customer ratings of online purchase intentions are influential, significant, and positive. Coefficient standardized regression weight for trend hashtag #RacunTiktok = 0.630, online customer reviews = 0.335, and online

customer ratings = 0.25, meaning trend hashtag #RacunTiktok, online customer reviews, and online customer ratings are influential, significant, and positive to online purchase intention. Online customer reviews are the most influential factor in online purchase intention. For that reason, the hypothesis first proved that trend hashtags #RacunTiktok, online customer reviews, and online customer ratings are influential and significant factors in online purchase intention.

**Table 7.** Hypothesis Testing

Variable	Direct Effect	P-value	Indirect Effect	Total Effect	Information
Trend The hashtag #RacunTiktok → Online Purchase Intentions	0.27	0.034	-	-	Significant
Online Customer Reviews → Online Purchase Intentions	0.31	0.006	-	-	Significant
Online Customer Ratings → Online Purchase Intentions	0.25	0.023	-	-	Significant
Trend The hashtag #RacunTiktok → Buying decision	0.28	0.015	-	-	Significant
Online Customer Reviews → Buying decision	0.22	0.022	-	-	Significant
Online Customer Ratings → Buying decision	0.30	0.002	-	-	Significant
Online Purchase Intentions → Buying decision	0.26	0.008	-	-	Significant

Variable trend the hashtag #RacunTiktok has a mark p-value of 0.015, online customer reviews have a mark p-value of 0.022, and online customer ratings have a mark p-value of 0.002 (<0.05), which means the trend hashtag #RacunTiktok, online customer reviews, and online customer ratings are influential, significant, and positive. Coefficient standardized regression weights for trend hashtags #RacunTiktok = 0.2, online customer reviews = 0.22, and online customer ratings = 0.30, meaning trend hashtag #RacunTiktok, online customer reviews, and online customer ratings are influential, significant, and positive to decision purchase. Online Customer Ratings most affect Decision Purchase, and with that hypothesis second proven, trend hashtags #RacunTiktok, online customer reviews, and online customer ratings are influential and significant to decision purchase. Variable online purchase intentions have a p-value of 0.008 (<0.05), which means online purchase intentions are influential and significant. Coefficient standardized regression weight = 0.26, meaning online purchase intentions influence positive decision purchase, with thereby the third hypothesis proven that online purchase intentions are influential and significant to decision purchase.

**Mediating Analysis Procedure**

The mediation testing process is carried out using the Sobel Test online. Based on the results of the online Sobel test, it shows that the t-statistic value (1,362) is smaller than the t-table value (1.96) and the p-value (0.173) is greater than the significance value (0.05). In addition, based on the results of the online Sobel test, it

shows that the t-statistic value (1,565) is smaller than the t-table value (1.96) and the p-value (0.117) is greater than the significance value (0.05). Based on Table 8, the Online Purchase Intentions test as mediation shows that there is no influence of Trend The hashtag # RacunTiktok on buying decisions through Online Purchase Intentions. This is evidenced by the t-statistical value of the Sobel test results, which is equal to 1.362, which means it is smaller than the t-table value (1.96) and the p-value is greater than the significance value (0.173 > 0.05).

**Table 8.** Indirect Effect Test Results

Variable	T-Statistic	P-Value	Information
Trend The hashtag # RacunTiktok → Online Purchase Intentions → Buying decision	1.362	0.173	No Mediation
Online Customer Reviews → Online Purchase Intentions → Buying decision	1.823	0.067	No Mediation
Online Customer Ratings → Online Purchase Intentions → Buying decision	1.565	0.117	No Mediation

Testing Online Purchase Intentions as mediation shows that there is no effect of Online Customer Reviews on Buying decisions through Online Purchase Intentions. This is evidenced by the t-statistical value of the Sobel test results, which is equal to 1,823 which means it is smaller than the t-table value (1.96) and the p-value is greater than the significance value (0.067 > 0.05). Testing Online Purchase Intentions as mediation shows that there is no influence of Online Customer Rating on Buying decisions through Online Purchase Intentions. This is evidenced by the t-statistical value of the Sobel test results, which is equal to 1.565, which means it is smaller than the t-table value (1.96) and the p-value is greater than the significance value (0.117 > 0.05). Thus, the fourth hypothesis is statistically rejected.

## Discussion

The hashtag trend #RacunTiktok has an impact on online purchase intention, meaning that the more often students view content displayed on TikTok, the more their online purchase intention can be increased in the TikTok Marketplace. The most appreciated indicator of the #RacunTiktok trend, in terms of increasing online purchase intention, is the interest in goods reflected in students buying TikTok shop products because they need those goods. Shows with the #RacunTikTok hashtag that appear are widely discussed so that other account users can be influenced and also enthusiastic about trying and then buying what has been recommended in the video. This is in line with the opinion of Purwati et al. (2021), which states that hashtags function to convey messages and are classified as social media. Generally, the video is equipped with a link that can be connected to the marketplace so as to generate interest in buying the products offered and generate online purchase intention.

Online customer reviews also have an impact on online purchase intention, meaning that better reviews from other users can increase online purchase intention. The most appreciated indicator of online customer reviews in increasing online purchase intention is perceived usefulness, which is reflected in online customer reviews making it easier for students to obtain product information. This

shows that online customer reviews are a tool for measuring product quality, service, and delivery time, because buyers cannot try the product directly. The customer's ability to review a product can lead to online purchase intention because online buyers only rely on product descriptions provided by sellers and reviews from other buyers. The results of this study support Gabriela and Mulyandi (2022); Harli et al. (2021); Mawa and Cahyadi (2021), who found that online customer reviews have an effect on online purchase intention.

Online customer ratings also have an impact on online purchase intention, meaning that the higher the rating given by the buyer on the marketplace, the more it can increase the online purchase intention. The most appreciated indicator of online customer ratings in increasing online purchase intention is perceived control, which is reflected in the high number of star scales that encourage students to make purchases. This is in line with the opinion of Putri (2021), which explains that online customer ratings are a measure of consumer opinion assessment related to product quality. This assessment reflects whether consumers are satisfied with the product that has been purchased and the quality of service provided by the seller. Thus, online customer rating becomes a material consideration for TikTok users to grow their online purchase intention. The results of this study support Gabriela and Mulyandi (2022); Harli et al. (2021); Mawa and Cahyadi (2021), who remarked that online customer ratings have an effect on online purchase intention.

In addition, the research results showed that the #RacunTikTok hashtag trend has a positive and significant effect on purchasing decisions. The more often consumers access the TikTok application and watch video content with the #RacunTikTok hashtag, the more it can generate interest and desire for an item being watched and result in a purchase decision. The results of this study are in line with the results of research conducted by Manurung et al. (2022), which stated that TikTok's toxic content influences purchase decisions in the Prefix community. Likewise, Rachmawati (2021) showed that the #RacunTikTok persuasion had a positive effect with a strong category on student consumptive behavior during the COVID-19 pandemic.

The research results also indicated that online customer reviews have a positive and significant effect on purchasing decisions. The existence of an online customer review feature makes it easier for consumers to obtain information about products according to the purchasing experience of other consumers. The results are in line with Sari (2021), which stated that online customer reviews and online customer ratings have a positive and significant effect on online purchasing decisions in e-commerce for UMSU students. In addition, Putri (2021) noted that online customer reviews and online customer ratings had a positive and significant effect on purchasing decisions through Lazada in Rumbio Jaya District. Indeed, Saskiana (2021) revealed that online customer ratings have a significant effect on the buying decisions of Shopee marketplace consumers in Surabaya. Likewise, research conducted by Lestari (2020) found that online customer reviews and online customer ratings have a positive effect with strong categories on marketplace consumer purchasing decisions.

The next finding showed that online purchase intention affects purchasing decisions, which means that the higher the interest of the University of Merdeka Malang students to consume the products seen on the TikTok application, the higher

the purchasing decisions on the TikTok marketplace. The indicator of online purchase intention that is most appreciated in improving purchasing decisions is transactional interest, as reflected in TikTok being the first choice because of its ease of access. This study provides information that shows female student respondents really like to explore new things. Trying new products through TikTok is one of them. Respondents really like practicality, starting from the practicality of product selection, how to order, and how to pay up to product delivery.

Marketplaces offer products with the practicality desired by consumers, causing students to want to make online purchases. Online purchase intention cannot be separated from the theory of consumer purchasing decisions, because interest is one of the final processes in consumer purchasing decisions. This is in accordance with the opinion of Schiffman and Kanuk (2007), who explained that purchase intention is something that represents a consumer who has the possibility to plan or be willing to buy a product or service in the future, and an increase in purchase intention means an increase in the possibility of purchase. Online purchase intention is an important thing to consider when deciding to buy a product.

The results of this study support Anuang and Korry (2020); Solihin (2020), who found that purchase intention influences purchase decisions. The next findings indicated that online purchase intention does not mediate the influence of the #RacunTiktok hashtag trend on purchase decisions in the TikTok Shop Marketplace for students of the University of Merdeka Malang. This shows that the #RacunTiktok hashtag trend has its own uniqueness and charm, so anyone who watches the video shows interest in buying the product. The hashtag trend #RacunTiktok, which is illustrated by interest in goods is reflected by students buying TikTok Shop products because they need these items so that they can increase online purchase intention. The results of this study do not support Manurung et al. (2022), who state that TikTok's toxic content influences purchasing decisions.

Online purchase intention does not mediate the influence of online customer reviews on purchase decisions in the TikTok Shop Marketplace for students of the University of Merdeka Malang. Online customer reviews play quite a role for consumers to find out how good the quality of the product they want to buy is, if the information needed by consumers is fulfilled, it can increase online purchase intention. If customers give good reviews, it will increase good consumer perceptions, which will attract the attention of other people who have never used the product so that they can increase online purchase intention, which has an impact on increasing purchasing decisions. The results of this study do not support Sari (2021) which stated that online customer reviews have an effect on online purchasing decisions. However, if customer reviews are not good, it will affect customer perceptions, which can cause new potential customers to be disinterested in the product, resulting in a decrease in purchasing decisions. The research results of Anuang and Korry (2020); Solihin (2020) prove that buying interest influences purchasing decisions.

Online purchase intention does not mediate the effect of online customer rating on purchasing decisions in the TikTok Shop Marketplace for the University of Merdeka Malang students. This shows that a high or low online customer rating has no impact on online purchase intention, because consumers buy according to their needs and desires, even though the large number of stars given by customers

indicates that the products offered are of high quality. The customer's assessment of the rating before deciding to buy something depends on how often the rating or assessment is done on a product. Rating a product online is one of the ways consumers think about the quality of online products. This is mainly due to product ratings by consumers, which reflect global consumer satisfaction, not only in the product but also in how consumers are served by online sellers. Thus, the number of ratings has no impact on purchasing decisions because consumers make purchases on the Marketplace because of the needs and benefits they get from the product as described on the Marketplace. The results of this study do not support Sari (2021) which remarked that online customer ratings have a positive and significant effect on online purchasing decisions.

## CONCLUSION

Based on the results and discussion, it can be concluded as follows Hashtag trends #RacunTiktok, online customer reviews, and online customer ratings have a positive and significant effect on online purchase intention on the TikTok Shop marketplace for students at the University of Merdeka Malang. Online customer reviews most influence online purchase intention; this indicates that with a product review, consumers can find out the information needed so that they can increase online purchase intention. Hashtag trends like #RacunTiktok, online customer reviews, and online customer ratings have a positive and significant effect on purchasing decisions in the TikTok Shop marketplace for college students at the University of Merdeka Malang.

Online customer ratings are the most influential factor in purchasing decisions, which indicates that the number of ratings is a consideration for consumers when making purchases. Online purchase Intention affects purchasing decisions in the TikTok Shop marketplace for students at the University of Merdeka Malang. This shows that a higher level of online purchase intention can improve the purchase decision. Hashtag trends #RacunTiktok, online customer reviews, and online customer ratings have no effect on purchasing decisions through online purchase intention in the TikTok Shop marketplace for students at the University of Merdeka Malang.

As other studies, this research has some limitations. The factors that influence purchasing decisions at the TikTok Shop marketplace in this study are limited to three variables, namely the #RacunTiktok hashtag trend, online customer reviews, and online customer ratings, while there are many other factors that can influence online purchase intention and purchase decisions at the TikTok Shop marketplace. The sample used in this study was limited to students at the University of Merdeka Malang. In this study, the data obtained only came from the results of the questionnaire instrument, so sometimes the answers given by respondents did not show the real situation. Therefore, the researchers provide the following suggestions. It is expected that they will examine more sources and references regarding the trend of the #RacunTiktok, online customer reviews, and online customer ratings. Future research is forecasted to expand the sample used so that respondents' answers will be more varied.

## REFERENCES

- Annur, C. M. (2022). Jumlah pengguna aktif bulanan tiktok global per kuartal II (2018-2022). *Datadoks*.
- Anuang, P. W. ., & Korry, P. D. P. (2020). Pengaruh adopsi teknologi dan social media marketing terhadap minat beli serta dampaknya terhadap keputusan pembelian (Studi pada perusahaan Niluh Djelantik). *TIERS Information Technology Journal*, 1(1), 25–32. <http://journal.undiknas.ac.id/index.php/tiers/index>
- Daulay, N. (2020). *Pengaruh online customer review dan online customer rating terhadap keputusan pembelian melalui marketplace Shopee (Studi pada masyarakat kecamatan Medan Labuhan)*. Universitas Sumatera Utara.
- Ferdinand, A. (2002). Kualitas strategi pemasaran: Sebuah studi pendahuluan. *Jurnal Sains Pemasaran Indonesia*, 1(1), 107–119. <https://doi.org/10.14710/jspi.v1i1.107-119>
- Gabriela, Y, & Mulyandi, M. R. (2022). Pengaruh online customer review dan online customer rating terhadap minat beli pelanggan e-commerce. *Jurnal Jempper : Jurnal Ekonomi, Manajemen Pariwisata dan Perhotelan*, 1(1), 121–125.
- Ghozali, I. (2018). *Aplikasi analisis multivariate dengan program IBM SPSS 25*. Badan Penerbit Universitas Diponegoro
- Hariyanto, H. T., & Trisunarno, L. (2021). Analisis pengaruh online customer review, online customer rating, dan star seller terhadap kepercayaan pelanggan hingga keputusan pembelian pada toko online di Shopee. *Jurnal Teknik ITS*, 9(2), 234–239. <https://doi.org/10.12962/j23373539.v9i2.56728>
- Harli, I. I., Mutasowifin, A., & Andrianto, M. S. (2021). Pengaruh online consumer review dan rating terhadap minat beli produk kesehatan pada e-marketplace Shopee selama masa pandemi COVID-19. *INOBISS: Jurnal Inovasi Bisnis dan Manajemen Indonesia*, 4(4), 558–572. <https://doi.org/10.31842/jurnalinobis.v4i4.205>
- Lestari, F. B. (2020). *Pengaruh online customer review dan online customer rating terhadap keputusan pembelian konsumen marketplace di Kota Tegal*. Universitas Pancasakti Tegal.
- Manurung, R. S. M., Dharta, F. Y., & Lubis, F. M. (2022). Pengaruh tayangan konten racun tiktok terhadap keputusan pembelian di komunitas Prefix. *Jurnal Ekonomi dan Bisnis*, 16(10), 7639–7646.
- Mawa, S. F., & Cahyadi, I. F. (2021). Pengaruh harga, online customer review dan rating terhadap minat beli di Lazada (Studi kasus mahasiswa Fakultas Ekonomi dan Bisnis Islam IAIN Kudus Angkatan 2017). *BISNIS: Jurnal Bisnis dan Manajemen Islam*, 9(2), 253–278. <https://doi.org/10.21043/bisnis.v9i2.11901>
- Melati, R. S., & Dwijayanti, R. (2020). Pengaruh harga dan online customer review terhadap keputusan pembelian case handphone pada marketplace Shopee (Studi pada mahasiswa Surabaya). *Jurnal Pendidikan Tata Niaga (JPTN)*, 8(2), 882–888. <https://forms.gle/t44jvKgVK6XAIzWi8>.
- Mumtaha, H. A., & Khoiri, H. A. (2019). Analisis dampak perkembangan revolusi industri 4.0 dan society 5.0 pada perilaku masyarakat ekonomi (E-Commerce). *Jurnal Pilar Teknologi : Jurnal Ilmiah Ilmu Teknik*, 4(2), 55–60.

- Priangga, I., & Munawar, F. (2021). Pengaruh online customer review dan online customer rating terhadap keputusan pembelian di marketplace Lazada (Studi pada mahasiswa di kota Bandung). *Jurnal Bisnis Manajemen & Ekonomi*, 19(2), 339–413.
- Purwati, P., Mulyana, E., & Aprily, N. M. (2021). Analisis pola penggunaan tagar viral sebagai media pendidikan karakter netizen (Studi kritis pada fenomena global mengenai tagar #dajjal di Twitter). *Journal Civics & Social Studies*, 5(1), 48–64. <https://doi.org/10.31980/civicos.v5i1.1071>
- Putri, M. (2021). *Pengaruh online customer review dan online customer rating terhadap keputusan pembelian melalui lazada di kecamatan Rumbio Jaya*. Universitas Islam Negeri Sultan Syarif Kasim Riau.
- Rachmawati, A. K. (2021). *Pengaruh persuasi #Racuntiktok terhadap perilaku konsumtif mahasiswa di masa pandemi Covid-19*. Universitas Pendidikan Indonesia.
- Rinaja, A. F., Udayana, I. B. N., & Maharani, B. D. (2022). Pengaruh online customer review, word of mouth, and price consciousness terhadap minat beli di Shopee. *Publik: Jurnal Manajemen Sumber Daya Manusia, Administrasi dan Pelayanan Publik*, 9(3), 435–448. <https://doi.org/10.37606/publik.v9i3.345>
- Sari, F. P. (2021). *Pengaruh online customer review dan online customer rating terhadap keputusan pembelian online di e-commerce pada mahasiswa Umsu*. Universitas Muhammadiyah Sumatera Utara Medan.
- Saskiana, D. (2021). *Pengaruh online customer review, online customer rating, e-service quality, e-trust dan harga terhadap keputusan membeli pada konsumen marketplace shopee di Surabaya*. Universitas Islam Negeri Sunan Ampel.
- Schiffman, L., & Kanuk, L. L. (2007). *Consumer behaviour*. Jakarta: PT. Indeks.
- Solihin, D. (2020). Pengaruh kepercayaan pelanggan dan promosi terhadap keputusan pembelian konsumen pada online shop mikaylaku dengan minat beli sebagai variabel intervening. *Jurnal Mandiri : Ilmu Pengetahuan, Seni, dan Teknologi*, 4(1), 38–51. <https://doi.org/10.33753/mandiri.v4i1.99>
- Wibowo, B. S., & Haryokusumo, D. (2020). Peluang revolusi industri 4.0 bidang pemasaran: Pemanfaatan aplikasi ecommrce, sosial media instagram dan digital marketing terhadap keputusan instant online buying konsumen generasi millennial. *Jurnal Ekonomi dan Manajemen*, 3(2), 87–99.